

askon



Redefining
Washroom Hygiene
since 1985

ABOUT US

Since its establishment in 1985, our company has been an industry leader in manufacturing high-quality hand dryers and washroom accessories. Our core strength lies in our ability to manufacture our products, allowing us to maintain strict quality control and ensure the excellence that our brand represents.

From day one, we have upheld a commitment to manufacturing top-tier products across our product portfolio. This dedication has been unwavering throughout our journey, underscoring our emphasis on quality and delivering exceptional customer service.

Our founder, Dr. Shreyas Shah, a seasoned medical practitioner, envisioned our company as a solution provider for hygiene needs, initially focusing on hospitals and operation theaters.

Over the span of three decades, our unyielding dedication and commitment have propelled us to the forefront of the industry. Today, we proudly stand as one of India's leading manufacturers and suppliers of washroom hygiene products

In a post-COVID world, clean public spaces are of paramount importance. Our adaptable products serve medical, commercial and hygiene needs across many sectors and industries.

Our legacy thrives on quality, excellence, and constantly innovating new products incorporating the latest technologies to meet the evolving customer demands.

OUR MISSION

Since our inception in 1985, our mission has been to deliver high quality hygiene products. Customer focus is built into all the aspects of our operations. From product design to after sales service, we make decisions keeping in mind the best interest of our customers.

User safety and environmental impact of our products are also very important considerations at our company. We aim to make products which are in operation for many years after installation and are easy to service & maintain. This is not only financially prudent for our customers but also better for the environment.

OUR JOURNEY

Founded by Dr. Shreyas Shah, our company initially addressed the specialized hygiene needs of hospitals and surgical suites. Over the course of three decades, our dedication and commitment have propelled us to emerge as a prominent manufacturer and supplier of washroom hygiene products in India.

In today's post-pandemic landscape, ensuring cleanliness and hygiene in public spaces has emerged as a paramount concern. Consequently, our products have garnered widespread acceptance not only in healthcare facilities but also in a variety of commercial and public spaces where hygiene is of the utmost significance.

OUR SET UP



PRODUCT ASSEMBLY



R&D



ELECTRONICS ASSEMBLY



PRODUCT ASSEMBLY

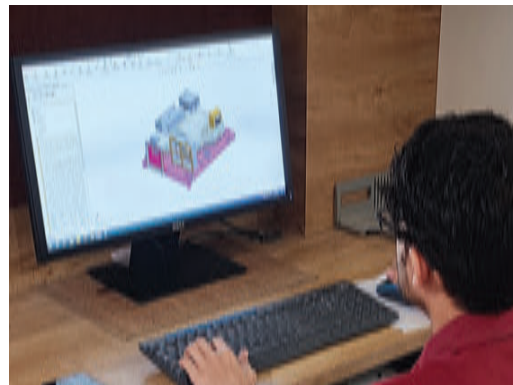

PRODUCT DESIGN

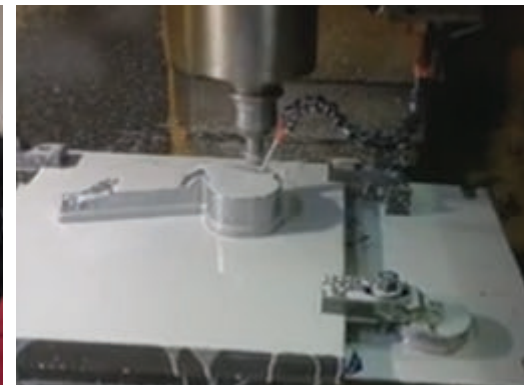

MOULD MAKING

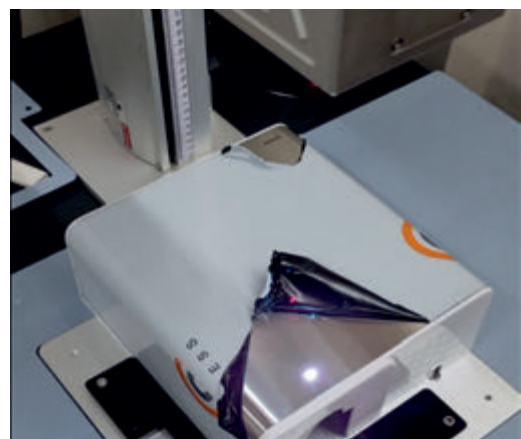

LASER MARKING



QC & TESTING

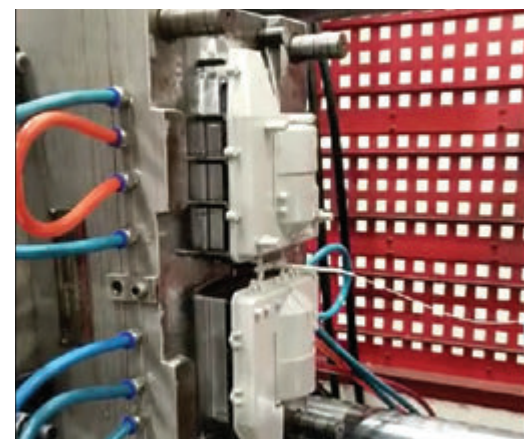

INJECTION MOULDING



OUR PRODUCT RANGE



- HAND DRYERS
- URINAL SENSORS
- SENSOR FAUCETS
- STAINLESS STEEL PANELS
- SHOE POLISH MACHINES
- SOAP & SANITIZER DISPENSERS
- PAPER TOWEL & TISSUE PAPER DISPENSERS
- BABY CHANGING STATIONS

SOME OF OUR ESTEEMED CLIENTS

askon



Model : ASH-VJ (G)

DUAL JET



ASH-MJ3

SALIENT FEATURES



Heater & Motor Control Switches



Brushless DC motor



HEPA Filter



Water tray

PRODUCT SPECIFICATIONS:

- **Power Supply:** 230 VAC, 50 Hz, Single Phase
- **Air Speed:** 100 m/s
- **Motor Type:** 33000 RPM, Brushless DC
- **Rated Power:** 700-900W (Heater OFF), 1850-2050W (Heater ON)
- **Drying Time:** 12 Seconds
- **Timing Protection:** 20 sec auto-cut off
- **Operation:** Fully automatic with IR sensors
- **Drip Proof:** IPX4
- HEPA Filter removes 99% dust and micro-organisms from intake air
- **Material:** Polycarbonate
- **Noise Level:** 78 db @ 1 mtr
- **Size:** H 700 x W 300 x D 215 mm
- Equipped with water tray, motor speed control and heating coil ON / OFF switches

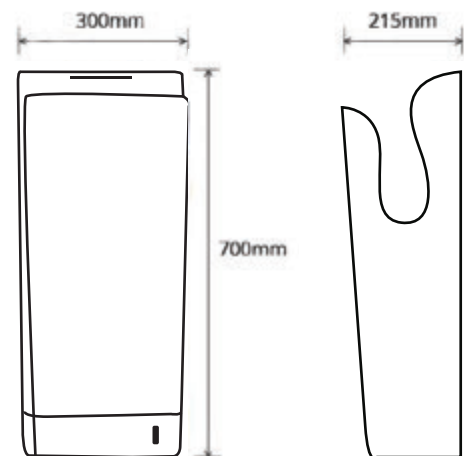

STAINLESS STEEL DUAL JET



ASH-MJ6-SS

PRODUCT SPECIFICATIONS:

- **Power Supply:** 230 VAC, 50 Hz, Single Phase
- **Air Speed :** 95 m/s
- **Motor Type:** 33000 RPM, Brushless DC
- **Rated Power:** 800W - 1650W
- **Drying Time:** 8-10 Seconds
- **Timing Protection:** 30 seconds auto-cut off
- **Operation:** Fully automatic with IR sensors
- **Drip Proof:** IPX4
- HEPA Filter removes 99% dust and micro-organisms from in take air
- **Material:** Stainless Steel # 304 + ABS Plastic
- **Stainless Steel Cover Thickness :** 1.2 mm
- **Noise Level:** 72 db @ 1 mtr
- **Unit Size:** H 730 x W 222 x D 300 mm
- Equipped with water tray to prevent water dripping on the floor
- Intelligent heating system to control the air heating

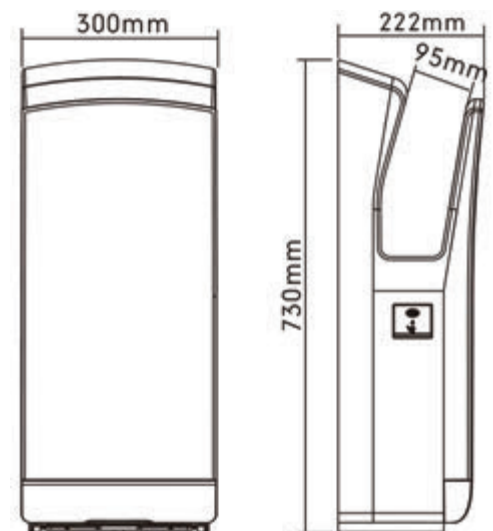

COMPACT DUAL JET



ASH-MJ4

PRODUCT SPECIFICATIONS:

- **Material:** Anti-Bacterial and Fire Retardant ABS
- **Power Supply:** 230 VAC, 50 Hz, Single Phase
- **Air Speed:** 90 m/s
- **Motor Type:** 31000 RPM, Brushless DC
- **Rated Power:** 700-900W (Heater OFF), 1600-1800 W (Heater ON)
- **Drying Time:** 20 Seconds
- **Timing Protection:** 30 seconds auto-cut off
- Heating coil and motor protected with thermal fuse and thermal cut-off
- **Operation:** Fully automatic with IR sensors
- **Drip Proof:** IPX4
- Equipped with HEPA filter to remove 99% dust and microorganisms from intake air
- Equipped with water tray and water level indicator LED which blinks when the tray is full
- **Noise Level:** 75 db @ 1 mtr
- **Size:** H 550 x W 285 x D 180 mm

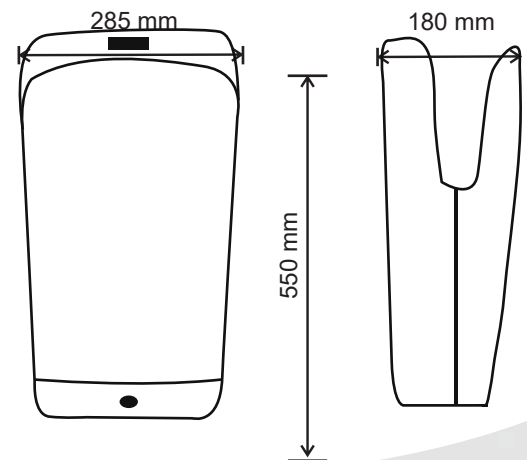

V JET



ASH-VJ (G)

V Jet Hand Dryer in Grey



ASH-VJ

V Jet Hand Dryer in White

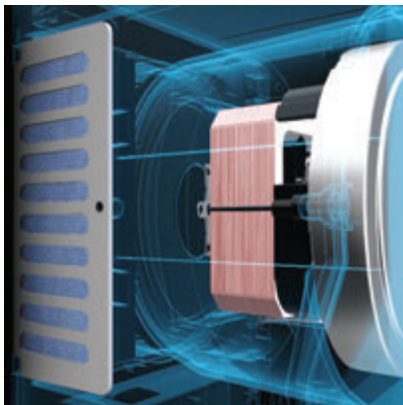

Does not use heating element.
Dries hands quickly with 75%
less power consumption
per hand drying cycle

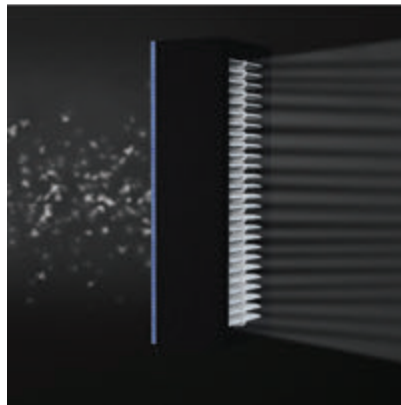

Two HEPA filters remove
99% impurities from intake
air. HEPA filters are easily
accessible from outside for
easy replacement

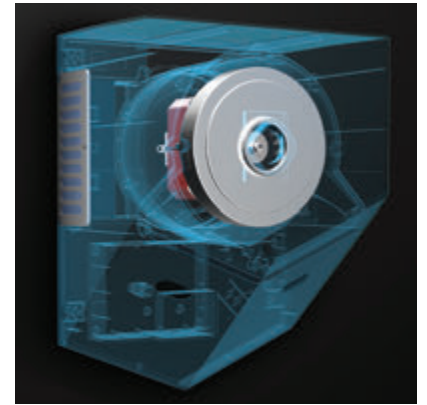

Powerful 30,000 RPM
motor generates high velocity
blades of air to dry hands
quickly.



V JET

PRODUCT SPECIFICATIONS:

- **Quick drying:** Dries hands in 12 seconds with 100 m/s air blades
- **Energy Efficient:** No heating element which saves 75% energy consumption
- Equipped with two anti-bacterial HEPA filters to remove 99% impurities from air
- **Rated Power :** 500 - 1000W (Depends on motor speed setting)
- Equipped with high-speed heavy-duty 30,000 RPM brushed motor
- Motor speed adjustable with switch
- **Fire Resistant:** Made with fire retardant and anti-bacterial plastics for utmost hygiene and safety
- Equipped with solid-state relays for longer operational life compared to mechanical relays
- Motor equipped with thermal fuse and cut-off
- **Size:** H 280 x W 210 x D 143 mm
- **Noise level:** 70 - 80 db (Depends on motor speed setting)
- **Operation:** Fully automatic with two IR sensors

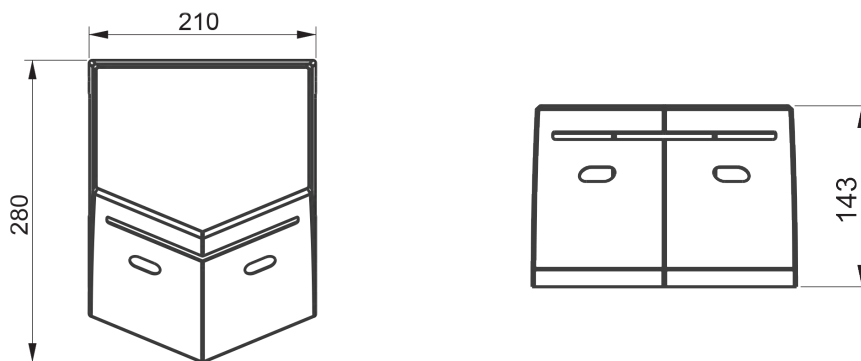

SAFETY SHUT DOWN FEATURE TO PREVENT MISUSE AND VANDALISM:

- After 5 seconds of continuous use, the hand dryer will enter into safety shutdown mode for 30 seconds.
- During these 30 seconds, the hand dryer will not start even if an object is present in front of the sensor.
- After 30 seconds, if the object is removed, the hand-dryer will function normally or will remain in shutdown mode.
- It is aimed at significantly reducing the machine downtime, damage and repair costs due to misuse.



INSTAJET™ PRO SERIES



AS 45-IR-G2-PRO-PW

Hand Dryer with fire
retardant plastic cover



AS 45-IR-G2-PRO-SB

Stainless steel hand dryer
with brush finish cover



AS 45-IR-G2-PRO-SM

Stainless steel hand dryer
with mirror finish cover



AS-45-IR-G2-PRO-W

Steel cover with
white enamel coating



INSTAJET™ PRO SERIES



PRODUCT SPECIFICATIONS:

- **Motor:** 40,000 RPM Heavy-duty brushed motor
- Operates automatically with IR sensors
- Uses Solid State relay for extended operational life
- **Outer Cover:**
 - Deep drawn Stainless Steel # 304 with brush finish for model : AS-45-IR-G2-SB
 - Deep drawn Stainless Steel # 304 with mirror finish for model : AS45-IR-G2-SM
 - White Fire Retardant ABS for model: AS-45-IR-G2-PW
 - Steel cover with white enamel coating for model: AS-45-IR-G2-W
- The motor and heating coil are protected with a thermal fuse and thermal cut-off
- **Construction:** Made from high-impact resistant engineering plastics, flame & heat retardant
- **Power Supply:** 230VAC, 50 Hz, Single Phase
- **Rated Power:** 775 W
- **Drip Proof** IP21
- **Air Speed:** 110 m/s
- **Air volume:** 450 m³/hr
- **Noise Level @ 1 metre:** 70 db - 80 db (depending on motor speed setting)
- **Drying time:** 8 - 10 seconds
- Heating Coil ON/OFF switch
- Motor speed adjustable with switch
- **Size:** H 270 x W 210 x D 133 mm
- Specially designed air filter & noise silencer
- **Timing Protection :** 45 seconds auto cut-off with patented safety shut-down feature to prevent misuse and vandalism of hand dryer

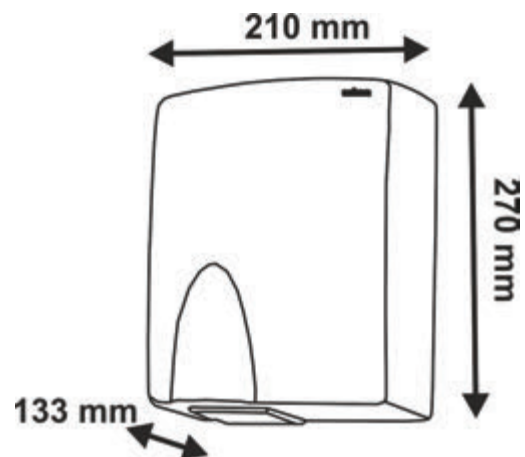

SAFETY SHUT DOWN FEATURE TO PREVENT MISUSE AND VANDALISM:

- After 45 seconds of continuous use, the hand dryer will enter into safety shutdown mode for 30 seconds.
- During these 30 seconds, the hand dryer will not start even if an object is present in front of the sensor.
- After 30 seconds, if the object is removed, the hand-dryer will function normally or will remain in shutdown mode.
- It is aimed at significantly reducing the machine downtime, damage and repair costs due to misuse.

SLIMJET™ PRO SERIES



AS 65-IR (SF)

PRODUCT SPECIFICATIONS:

- **Motor:** Heavy duty high speed brushed motor, 25000 RPM
- Operates automatically with IR sensors
- Uses solid state relay for extended operating life
- The motor and heating coil are protected with thermal fuse and thermal cut off
- **Outer Cover:**
Stainless Steel # 304 + FR ABS plastic
- **Construction:** Made from high impact resistant engineering plastics, flame retardant UL-94 V-0
- **Impeller:** Curved blade impeller made from high impact polycarbonate
- **Power Supply:** 230VAC, 50 Hz, Single Phase
- **Rated Power:** 900 W **Rated Current:** 3.91 A
- **Air Speed:** 90 m/s ; **Air volume:** 245 m³/hr
- **Noise Level @ 1 mtr:** 70 db
- **Size:** H 266 x W 238 x D 113 mm
- **Operation:** Fully automatic with two IR sensors
- **Timing Protection :** 45 seconds auto cut-off with patented safety shut-down feature to prevent misuse and vandalism of hand dryer



Energy Efficient:
Every hand drying cycle consumes only 0.003 units of power

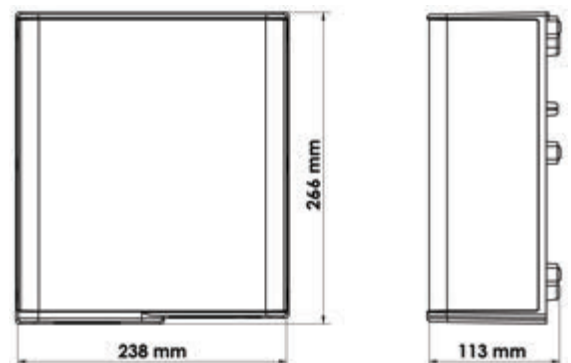

SINGLE BLOWER



AS 45-IR (W)

Steel cover with white enamel coating



AS 45-IR (SB)

Stainless steel cover with brush finish



AS 45-IR (SM)

Stainless steel cover with mirror finish



AS 45-IR (PW)

Fire retardant plastic cover

PRODUCT SPECIFICATIONS:

- Fully automatic with IR Sensor
- **Outer Covers:**
 - Deep drawn Stainless Steel # 304 with brush finish for model AS 45-IR (SB)
 - Deep drawn Stainless Steel # 304 with mirror finish for model AS 45-IR (SM)
 - White Fire Retardant ABS for model AS 45-IR (PW)
 - Steel cover with white enamel coating for model AS 45-IR (W)
- Internal components of fire retardant polycarbonate plastics with anti-microbial additives for utmost hygiene & safety
- **Power :** 1050 W • **Noise Level :** 70 db @1m
- **Power Supply:** 230 VAC, 50Hz, Single Phase
- **Heating Coil :** Spiral wound kanthal heating element.
- **Motors :** Brushless AC motor, 2850 RPM
- **Maximum air temperature at outlet :** 70°C
- **Size:** H 270 x W 210 x D 115 mm
- **Timing Protection :** 45 seconds auto cut-off with patented safety shut-down feature to prevent misuse and vandalism of hand dryer

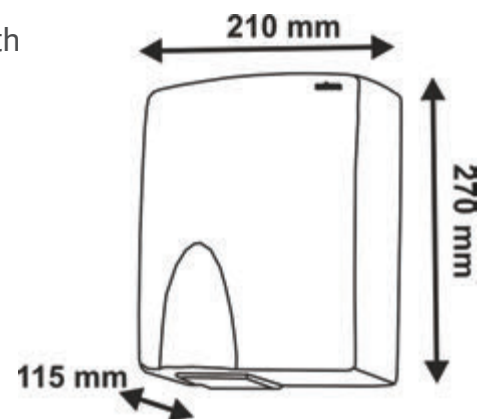

TWIN BLOWER



AS 25-IR (SB)

Stainless steel cover
with brush finish



AS 25-IR (SM)

Stainless steel cover
with mirror finish



AS 25-IR (W)

Steel cover with
white enamel coating

PRODUCT SPECIFICATIONS:

- Fully automatic with IR Sensor
- **Outer Covers:**
Deep drawn Stainless Steel # 304 with brush finish for model AS 25 - IR (SB)
Deep drawn Stainless Steel # 304 with mirror finish for model AS 25 - IR (SM)
Steel cover with white enamel coating for model AS 25 - IR (W)
- **Size:** H 220 x W 290 x D 145 mm
- **Type:** Twin Blower with two motors and heating coils
- **Power:** 1400W
- **Power supply:** 230VAC.50 Hz Single Phase
- **Heating element:** Two Spiral wounds, Kanthal Make with resetting thermal cut-offs and thermal fuse enhanced safety
- **Impellers:** Two aluminum impellers, Dynamically Balanced
- **Motor:** Two Shaded pole induction motors with thermal fuses for enhanced safety, 2850 RPM
- **Max Air temperature at outlet :** 70° C
- **Timing Protection :** 45 seconds auto cut-off with patented safety shut-down feature to prevent misuse and vandalism of hand dryer

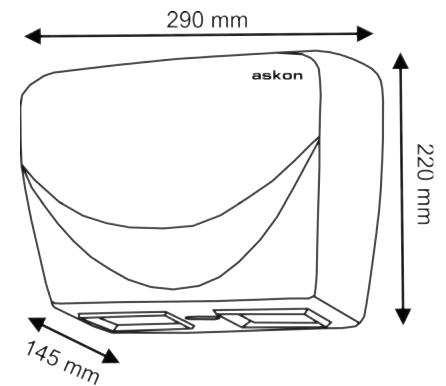

SLIMJET™ SERIES



AS 55-IR (SF)



AS 55-IR (W)

PRODUCT SPECIFICATIONS:

- **Motor:** High speed brushed motor, 15000 RPM
- Operates automatically with IR sensors
- The motor and heating coil are protected with thermal fuse and thermal cut off
- **Outer Cover:**
Stainless Steel # 304 + ABS plastic for model AS 55-IR (SF)
ABS plastic cover for model AS 55-IR (W)
- **Construction:** Blower and impeller in polycarbonate, all other parts in ABS plastic
- **Power Supply:** 230VAC, 50Hz, 1 Phase
- **Rated Power:** 850 W
- **Rated Current:** 3.69 A
- **Noise Level @ 1 mtr:** 70 db
- **Air Speed:** 70 m/s
- **Air volume:** 180 m³/hr
- **Size:** H 266 x W 238 x D 113 mm
- **Timing Protection :** 45 seconds auto cut-off with patented safety shut-down feature to prevent misuse and vandalism of hand dryer

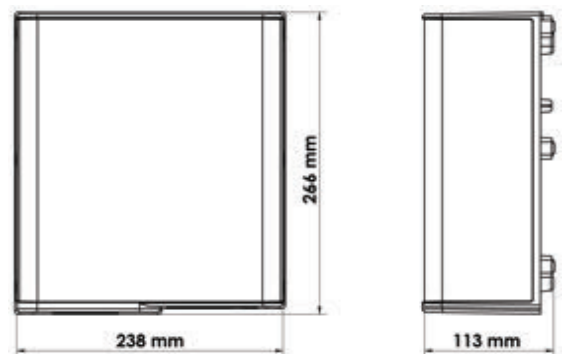

COMPACT PLASTIC



AS 15-IR (W)

ABS Plastic Hand Dryer
in white colour

PRODUCT SPECIFICATIONS:

- Power Supply: 230 V, 50Hz, Single Phase
- Power Consumption: 700 W
- Outer Cover: ABS Plastic
- Construction: Fire retardant Polycarbonate for extra durability and safety
- Noise Level: 70 db @ 1 meter
- Motor: Brushless AC Motor, 2850 RPM.
- Spiral wound Kanthal heating element.
- Maximum air temperature at outlet: 70
- Aluminium Impeller, dynamically balanced^{°C}
- Heavy Duty Design suitable for installation at all types of facilities.
- **Timing Protection** : 45 seconds auto cut-off with patented safety shut-down feature to prevent misuse and vandalism of hand dryer

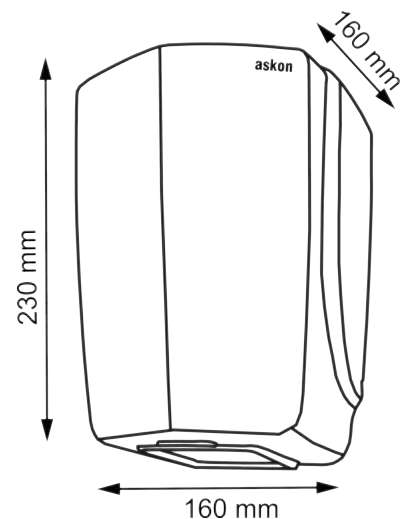



AS 05-IR

Die casting front plate



AS 06-IR / AS 08-IR

SS # 304 front plate



AS 07-IR / AS 09-IR

SS # 304 front plate

CONCEALED BOXES



AS 05-IR



AS-06IR



AS 07-IR

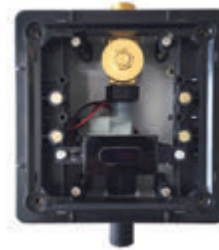

AS 08-IR



AS 09-IR

PRODUCT SPECIFICATIONS:

- Concealed type
- Aluminium die-casting front plate for AS 05-IR
S.S. #304 front plate for AS 06-IR / AS 07-IR / AS 08-IR / AS 09-IR
- Size of front plate:
For AS 05-IR: W 150 x H 150 x D 11 mm
For AS 06-IR / AS 07-IR / AS 08-IR / AS 09-IR : W 150 x H 150 x D 8 mm
- 230V A/C Single phase for electrical type and 6VDC (4 'AA' alkaline batteries) for battery type
- The electronic circuit is completely sealed with resin to prevent damage due to moisture
- Size of Polycarbonate concealed box : H 130 x W 130 x D 72 mm
- Brass solenoid valves for AS 06-IR / AS 07-IR
- Brass flow control valve in the concealed box for all models
- Nylon solenoid valves for AS 05-IR / AS 08-IR / AS 09-IR
- 1/2" B.S.P Inlet and outlet connections • 360° Debris screen (filter)
- Sensing range and flush duration to be adjusted with remote (common remote for multiple units)
- Suffix (E) stands for Electrical version & (B) stands for battery version
- Wire connectors are water proof





ASU-30B

PRODUCT SPECIFICATIONS:

- Chrome plated brass body and fully automatic with IR sensors
- Built-in water flow regulator valve allows water to be adjusted and turned off as desired.
- Built-in water filter unit protect solenoid valve
- Electronic control components are filled with resins and sealed to give moisture free life.
- Water inlet & outlet connection - 1/2" B. S. P.
- Use of four "AAA" size ALKALINE 1.5 V batteries (DC6V)
- Sensing adjusts automatically according to ambient conditions

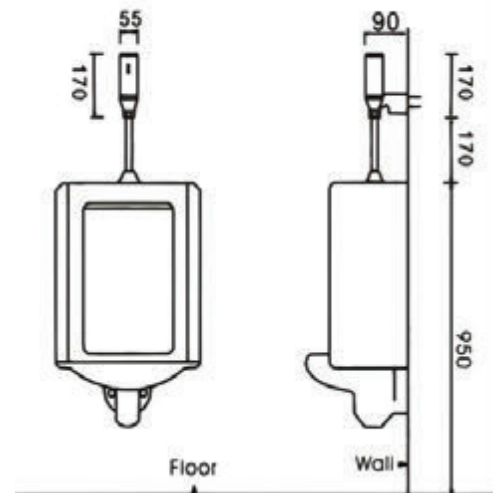



ASF-70 (E) / ASF-70 (B)

PRODUCT SPECIFICATIONS:

- Counter or basin mount type
- Chrome plated brass faucet with IR sensors
- Magnetic solenoid latching valve with piston valve technology
- 230 Volts, A/C single phasepower supply for ASF-70E
- Use of four "AA" size ALKALINE 1.5 V batteries (DC6V) for ASF-70B
- Sensor & PCB are sealed to prevent damage due to moisture
- Sensing range adjusts automatically to surroundings
- 1/2" B.S.P. input and output water supply connection
- Optional low flow water saving aerators to reduce water consumption
- Min. water pressure: 15 psi
- Max. water pressure: 80 psi
- Shut-off water pressure: 7 psi
- Sensor equipped battery low LED indicator

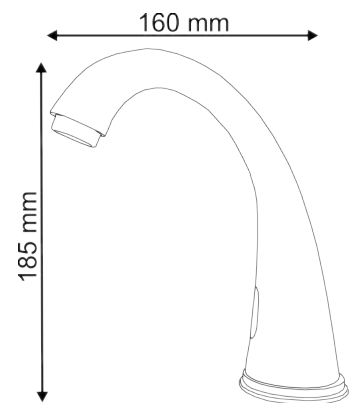



ASF-03 (E) / ASF-03 (B)

PRODUCT SPECIFICATIONS:

- Wall mount type
- Chrome plated brass faucet with IR sensors at the tip of the faucet
- Magnetic solenoid latching valve with piston valve technology
- 230 Volts, A/C single phase power supply for ASF-03E
- Use of four "AA" size ALKALINE 1.5 V batteries (DC6V) for ASF-03B
- Sensor & PCB are sealed to prevent damage due to moisture
- Sensing range adjusts automatically to surroundings
- 1/2" B.S.P. input and output water supply connection
- Min. water pressure: 15 psi
- Max. water pressure: 80 psi
- Shut-off water pressure: 7 psi
- Sensor equipped with battery low LED indicator

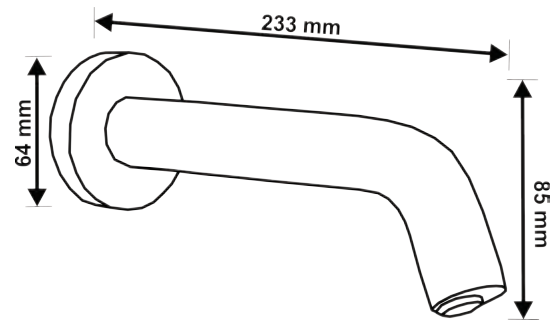



ASF-04 (E) / ASF-04 (B)

PRODUCT SPECIFICATIONS:

- Counter or basin mount type
- Chrome plated brass faucet with IR sensors
- Magnetic solenoid latching valve with piston valve technology
- 230 Volts, A/C single phase power supply for ASF-04E
- Use of four "AA" size ALKALINE 1.5 V batteries (DC6V) for ASF-04B
- Sensor & PCB are sealed to prevent damage due to moisture
- Sensing range adjusts automatically to surroundings
- 1/2" B.S.P. input and output water supply connection
- Min. water pressure: 15 psi
- Max. water pressure: 80 psi
- Shut-off water pressure: 7 psi
- Sensor equipped battery low LED indicator

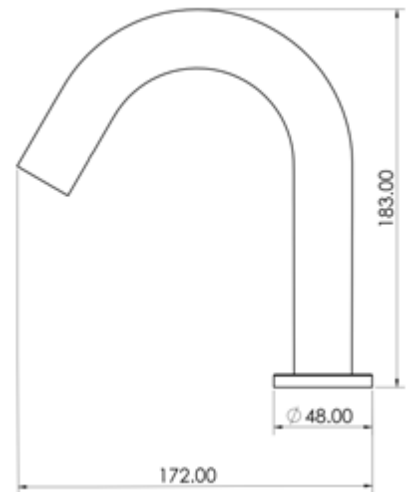



ASF-05 (E) / ASF-05 (B)

PRODUCT SPECIFICATIONS:

- Counter or basin mount type
- Chrome plated brass faucet with IR sensors
- Magnetic solenoid latching valve with piston valve technology
- 230 Volts, A/C single phase power supply for ASF-05E
- Use of four "AA" size ALKALINE 1.5 V batteries (DC6V) for ASF-05B
- Sensor & PCB are sealed to prevent damage due to moisture
- Sensing range adjusts automatically to surroundings
- 1/2" B.S.P. input and output water supply connection
- Min. water pressure: 15 psi
- Max. water pressure: 80 psi
- Shut-off water pressure: 7 psi
- Sensor equipped battery low LED indicator

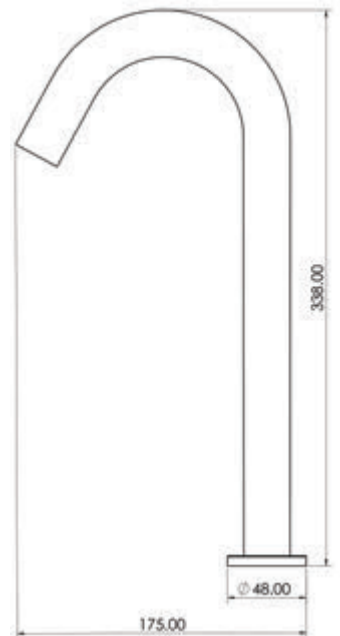



ASF-50 (E) / ASF-50 (B)

PRODUCT SPECIFICATIONS:

- Counter or basin mount type
- Chrome plated brass faucet with IR sensors
- Magnetic solenoid latching valve with piston valve technology
- 230 Volts, A/C single phase for ASF-50E
- Use of four "AA" size ALKALINE 1.5 V batteries (DC6V) for ASF-50B
- Sensor & PCB are sealed to prevent damage due to moisture
- Sensing range adjusts automatically to surroundings
- 1/2" B.S.P. input and output water supply connection
- Optional low flow water saving aerators to reduce water consumption
- Min. water pressure: 15 psi
- Max. water pressure: 80 psi
- Shut-off water pressure: 7 psi
- Sensor equipped with battery low LED indicator

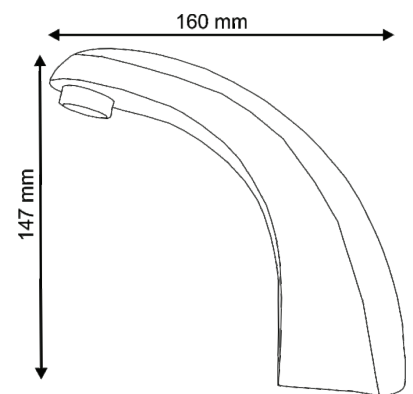



ASF-06 (E) / ASF-06 (B)

PRODUCT SPECIFICATIONS:

- Counter or basin mount type
- Chrome plated brass faucet with IR sensors
- Magnetic solenoid latching valve with piston valve technology
- 230 Volts, A/C single phase power supply for ASF-06E
- Use of four "AA" size ALKALINE 1.5 V batteries (DC6V) for ASF-06B
- Sensor & PCB are sealed to prevent damage due to moisture
- Sensing range adjusts automatically to surroundings
- 1/2" B.S.P. input and output water supply connection
- Optional low flow water saving aerators to reduce water consumption
- Min. water pressure: 15 psi
- Max. water pressure: 80 psi
- Shut-off water pressure: 7 psi
- Sensor equipped with battery low LED indicator

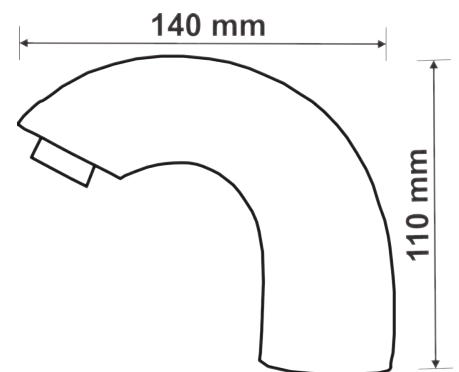

STAINLESS STEEL MULTI-PURPOSE PANELS

askon

3-IN-1 CONCEALED PANEL (TISSUE PAPER DISPENSER + HAND DRYER + WASTE CONTAINER)

ASM-25T

PRODUCT SPECIFICATIONS:

- Stainless steel # 304 grade, brushed (satin) finish, 22 gauge (0.8 mm) panel for concealing in the wall
- Durable spot welded construction, common key for three tumbler locks, doors equipped with heavy duty hinges
- Paper towel dispenser holds 800 multi fold or 600 c-fold paper towels
- Removable stainless steel waste container having capacity of 23 liters
- Size: H 1650 x W 350 x D 150 mm

HAND DRYER SPECIFICATIONS:

- Stainless steel hand dryer with brush finish
- Voltage: 230V - 50Hz • Power: 1000 W
- Air speed: 90 m/s
- High Speed Universal carbon brush motor, 30000 RPM
- Motor equipped with thermal cut-off & heating coil equipped with thermal cut-off and thermal fuse for overheating protection.

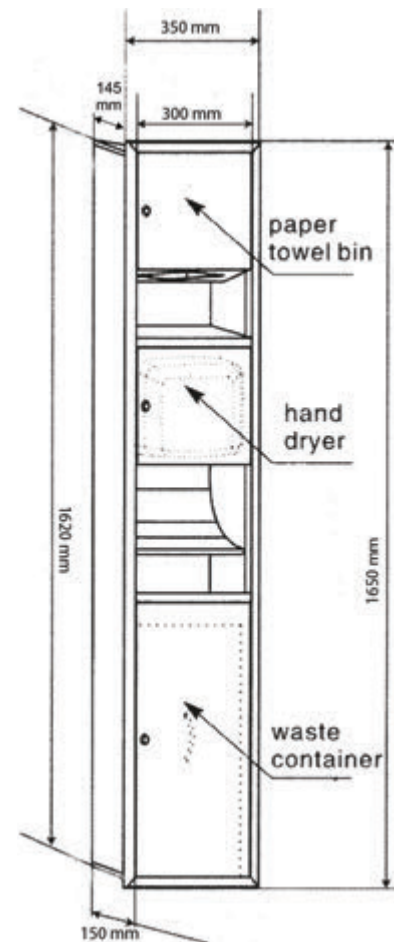



ASD-130AD (Drop Type) / ASD-130AS (Spray Type)*

- Made from high impact ABS Plastic
- Operates using 4 'C' size alkaline batteries
- Tank Capacity :1000 ml
- Equipped with lock and key for security
- Size: H 276 x W 151 x D 110 mm
- ON/OFF switch
- 6V DC Adaptor can be used



ASD-110AD (Drop Type) / ASD-110AS (Spray Type)*

- Made from high impact ABS Plastic
- Powered by 4 'AA'-size alkaline batteries
- Tank capacity: 1100 ml
- Equipped with lock and key for security
- Size: H 235 x W 140 x D 107 mm



ASD-120AD (Drop Type) / ASD-120AS (Spray Type)*

- Made from high impact ABS Plastic
- Runs on 4 'C' size alkaline batteries
- Contains 1000 ml of soap
- Lock and key included for security
- Size: H 260 x W 120 x D 110 mm
- ON/OFF switch
- 6V DC Adaptor can be used



ASD-210AS (Spray Type)*

- Made from high impact ABS Plastic
- Powered by 230 VAC, 50 Hz, Single Phase with provided adaptor
- Large 2100 ml capacity
- Lock and key included for security
- Adjustable angle for spray nozzle
- Spray volume adjustable from 0.5-3 ml per operation
- Size: H 320 x W 185 x D 130 mm

AS-SV



- Wall Mounted with easy installation
- Extremely durable construction
- Volume: 1000 ml
- Material: Stainless Steel # 304 Grade
- Size: H 195 X W 115 X D 85 mm
- Pump is easily replaceable
- Provided with lock and key

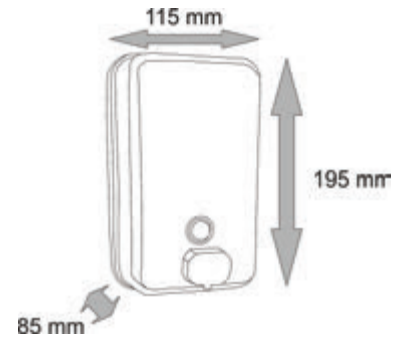

AS-SS (N)



- Wall Mounted with easy installation
- Extremely durable construction
- Volume: 1500 ml
- Material: Stainless Steel # 304 Grade
- Size: H 200 X W 120 X D 140 mm
- Pump is easily replaceable
- Provided with lock and key
- Viewing window for soap level

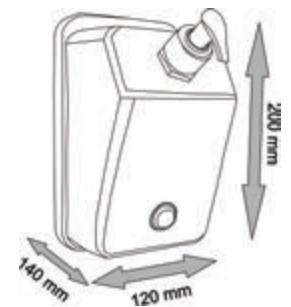

AS-SP



- Wall mounted type
- Elegant design, durable construction
- Material : Stainless steel # 304 Grade, brush finish
- Provided with lock and key
- Viewing window for soap level
- Size : H 260 x W 115 x D 100 mm
- Volume : 1000 ml
- Pump & bottle is easily replaceable

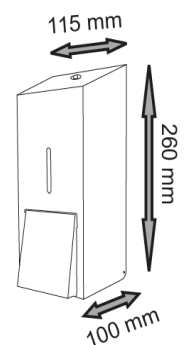



AS-CM (Counter mount type)

- Piston, spout & top cap made from Stainless Steel # 304
- Bottom cap made from ABS plastic with chrome plating
- Housing and bottle nut made of high impact nylon
- Retaining nut of ABS plastic
- White rubber washer of Silicone and Black rubber washer of Nitrile
- Bottle Capacity : 600 ml

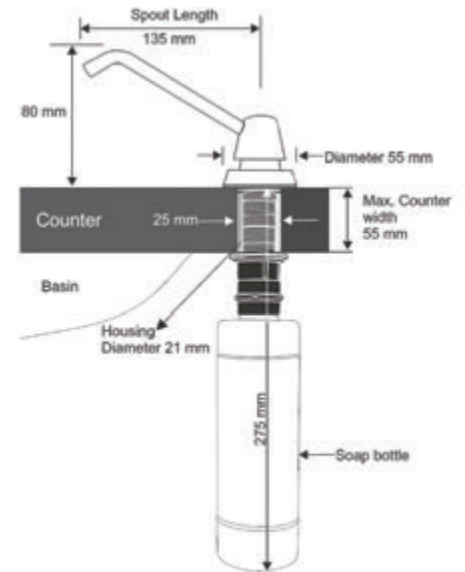

ASD-36W

- Made from durable ABS plastic
- Holds 360 ml of soap
- Size: H 90 x W 80 x D 82 mm
- Compact design with anti-theft lock
- Viewing window for soap level

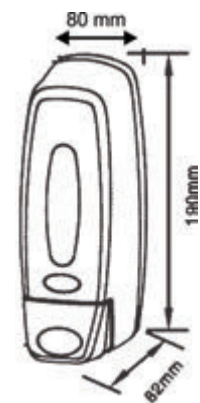

SHOE POLISH MACHINE

WITH TOUCH BUTTON OPERATION AND
STAINLESS STEEL SUPPORT BAR



ASM-50T

PRODUCT SPECIFICATIONS:

- Made of steel & stainless steel for enhanced durability and longer product life as compared to other wooden frame shoe polish machines.
- Powder coating for enhanced durability and protection against corrosion.
- Features a stainless steel # 304 support bar with a touch start button
- Offers easy access to brushes from the sides
- Equipped with a 15-second auto timer cut-off
- **Brush Size:** Dia 130, W 75 mm
- Separate brushes for black and brown shoes
- **Size:** H 265 x W 390 x D 220 mm
- **Support Bar size:** H 750 , Dia 32 mm
- Powerful 1400 RPM motor

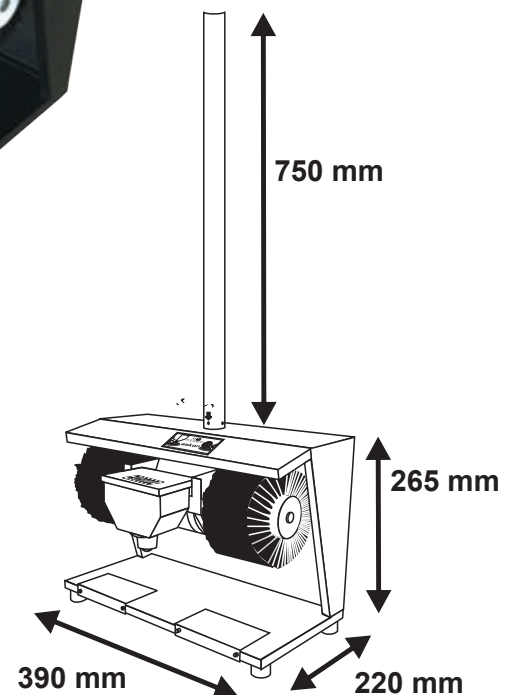

SHOE POLISH MACHINE AUTOMATIC SENSOR OPERATED



ASM-60

PRODUCT SPECIFICATIONS:

- Made of steel & stainless steel for enhanced durability and longer product life as compared to other wooden frame shoe polish machines.
- Fully Automatic with shoe polish cream dispenser
- Powerful 1400 RPM motor
- **Brush Size:** 75 mm width & 130 mm dia
- **Voltage:** 230 volts, 50 Hz
- **Size:** H 245 x W 490 x D 165 mm
- Powder coating for enhanced durability and protection against corrosion.
- Sleek compact design so it can fit almost anywhere.

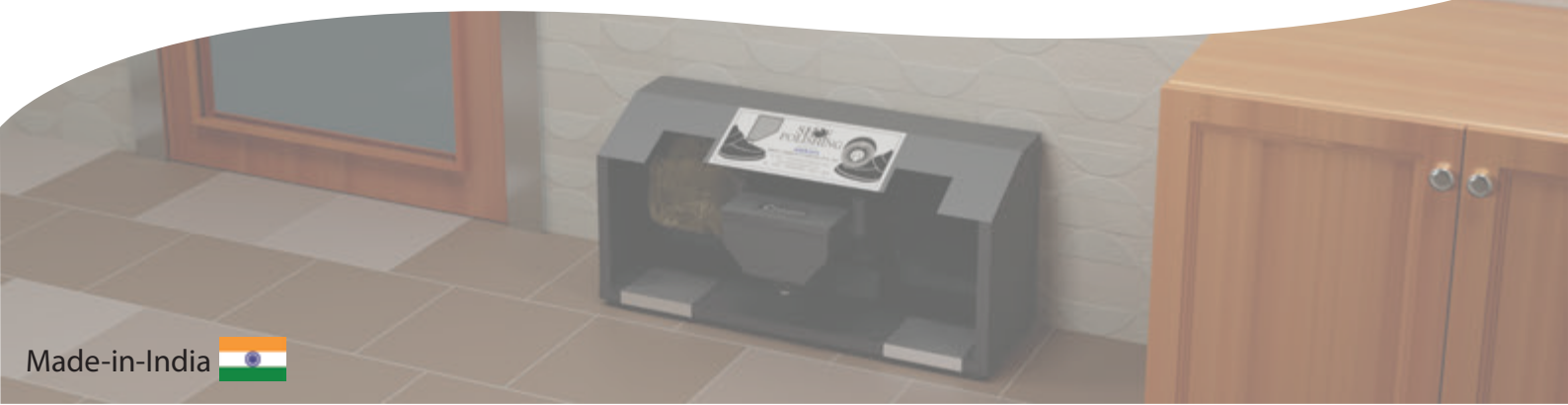
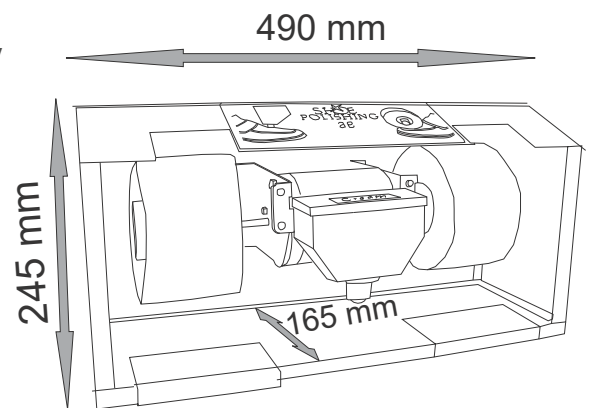



AST-30SL

- Material: S.S. # 304 with brush finish
- Equipped with lock and key
- Holds 500 multi-fold towels
- Size: H 369 x W 280 x D 102 mm



AST-30SS

- Material: S.S. # 304 with brush finish
- Equipped with lock and key
- Holds 250 multi-fold towels
- Size: H 203 x W 280 x D 102 mm



AST-60PL

- Made from high impact ABS plastic
- Holds 500 multi fold towels
- Equipped with lock and key
- Size: H 385 x W 280 x D 115 mm



AST-40PS

- Made from high impact ABS plastic
- Holds 250 multi fold towels
- Size: H 210 x W 270 x D 95 mm



AST-30SR

- Material: S.S. # 304 with brush finish
- Equipped with lock and key
- Suitable for standard jumbo tissue rolls
- Size: H 273 x W 275 x D 120 mm



AST-100PJ

- Made from high impact ABS plastic
- Suitable for standard jumbo tissue rolls
- Equipped with lock and key
- Size: H 298 x W 283 x D 110 mm

STAINLESS STEEL BABY CHANGING STATION (WALL MOUNT)



AS-BCS-01SS

PRODUCT SPECIFICATIONS:

- Horizontal, Stainless steel clad, Surface Mounted, opens when required
- Safety Belt with cam-buckle, adjustable with one hand
- **Maximum load:** 30 kgs
- Gas spring mechanism ensures controlled, safe and smooth opening and closing
- Hygienic and easy to clean HDPE material
- The station has minimal protrusion freeing up valuable space in washrooms
- Heavy duty design ensures safe and stable platform for changing babbies and toddlers
- **Material:** Stainless Steel + HDPE
- **Dimensions:**
Open: L 940 x H 520 x D 495 mm
Closed: L 940 x H 520 x D 104 mm
- **Unit Weight:** 23 Kgs
- **Installation Height:** Bottom edge of unit to be 800 mm from floor level

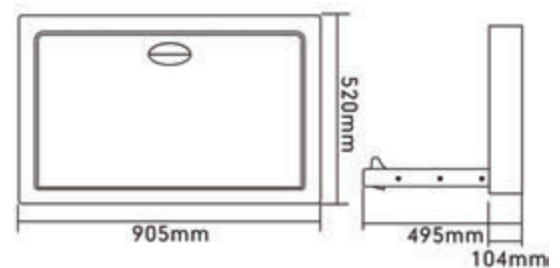

STAINLESS STEEL BABY CHANGING STATION (RECESSED WALL MOUNT)



AS-BCS-02RSS

PRODUCT SPECIFICATIONS:

- Horizontal, Stainless Steel clad, recessed mounted, opens when required
- Safety Belt with cam-buckle, adjustable with one hand
- Maximum load: 30 kgs
- Gas spring mechanism ensures controlled, safe and smooth opening and closing
- Hygienic and easy to clean HDPE material
- The station has minimal protrusion freeing up valuable space in washrooms
- Heavy duty design ensures safe and stable platform for changing babbies and toddlers
- **Material:** Stainless Steel + HDPE
- **Dimensions:**
Open: L 940 x H 585 x D 495 mm
Closed: L 940 x H 585 x D 104 mm
- **Unit Weight:** 22 Kgs
- Installation Height: Bottom edge of unit to be 800 mm from floor level

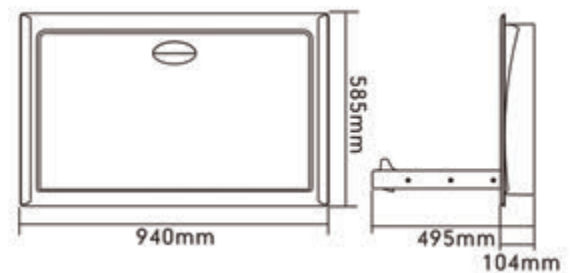

BABY CHANGING STATION (WALL MOUNT)



AS-BCS-03P

PRODUCT SPECIFICATIONS:

- Horizontally mounted design, opens when required
- Safety Belt with cam-buckle, adjustable with one hand
- Maximum load: 30 kgs
- Gas spring mechanism ensures controlled, safe and smooth opening and closing
- Hygienic and easy to clean HDPE material
- Heavy duty design ensures safe and stable platform for changing babbies and toddlers
- Two bag hooks provide a hygienic place to rest belongings whilst changing the baby.
- Ultra safe, slimline design that takes up little space with no sharp edges or corner
- **Material:** HDPE
- **Dimensions:**
Open: L 855 x H 560 x D 495 mm
Closed: L 855 x H 560 x D 107 mm
- **Unit Weight:** 12 Kgs
- **Installation Height:** Bottom edge of unit to be 800 mm from floor level

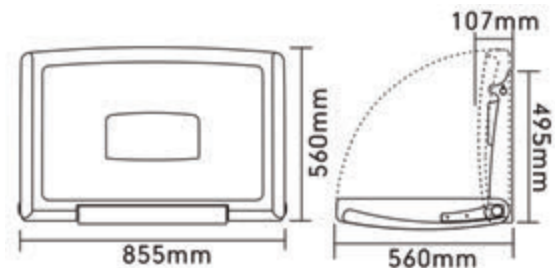

WHY CHOOSE askon?



35+ YEARS OF EXPERTISE

Benefit from our extensive experience in sensor-operated washroom products, a testament to our industry leadership.



TRUSTED BRAND

Leading companies, architects, and consultants trust us for our quality and reliability.



MADE IN INDIA

Range of locally manufactured high-quality products.



PAN INDIA PRESENCE

Our widespread network ensures timely assistance and support across the country.



SAFETY ABOVE ALL

User safety drives our designs, ensuring secure experiences.



CONTINUOUS IMPROVEMENT

We constantly incorporate latest advancements in products and processes to exceed your evolving expectations.



COMPREHENSIVE SOLUTION

As India's sole integrated solution provider, we offer a unique combination of design, manufacturing and service.



PREMIUM QUALITY

Use of premium materials for our products for unmatched performance and longevity.

askon

Your partner for all
hygiene solutions

CONTACT US TODAY!



info@askonhygiene.com



www.askonhygiene.com



+91-99303 89999



120, Keytuo Industrial Estate, Kondivita Road, Andheri (East), Mumbai-400059